

	Test report n.	813-QL18-R01 ver.0
	Applicant/ Antragsteller	Fondmetal S.p.A. Via Bergamo, 4 24050 Palosco (BG) Italy
	EUT/Type	PKW-Rad - Type FMI04_9520

**GUTACHTEN über die Dauerfestigkeit von Rädern**  
Strength Certificate for Wheels

**Nr. 813-QL18-R01 ver.0**

<b>Adressen</b> Addresses		
Antragsteller Applicant	Fondmetal S.p.A. - Via Bergamo, 4 - 24050 Palosco (BG) Italy	
Hersteller Manufacturer	YHI Manufacturing (Malaysia) Sdn. Bhd. - 3533, Jalan P.B.R 28, Kawasan Perindustrian Bukit Rambai , 75250 Melaka, Malaysia	
Prüflabor Test laboratory	Qualilab s.r.l. Via Trento, 87 25020 – Capriano del Colle (BS)	
<b>Daten und Berechtigungen</b> Dates and authorization		
Datum Bericht und Test Report and test date	Siehe Punkt VI / See point VI	
Unterschriften Authorization	Giuliano Pizzamiglio Testing Engineer	 
	Ing. Carsten Seyring Reviewer	
<b>Prüfgegenstand (Herstellerangaben)</b> Equipment under test (declared by the applicant)		
Prüfgegenstand Description equipment under test	PKW-Rad /Wheel for Passenger Cars	
Typ Type	FMI04_9520	
Modell Model	-	
Radgröße Wheel dimension	9,5Jx20 EH2+	
<b>Anzuwendende Normen</b> Applicable norms		
<p>Die Dauerfestigkeit, der hier beschriebenen Räder, wurde gemäss der "Richtlinien für die Prüfung von Sonderrädern für Kfz und ihren Anh. BMV/StV 13/36.25.07-20.01, VkB1 S 1377" vom 25.11.1998 und ECE-R 124 Änd. 00 Erg. 01 geprüft.</p> <p>The strength resistance of the wheels described in this report were tested in accordance with the "guidelines for the testing and inspection of special wheels for motor vehicles and their trailers BMV/StV 13/36.25.07-20.01, VkB1 S 1377" from 25<sup>th</sup> of November 1998 and ECE-R 124 Supp. 00 amend. 01</p>		

The test results and observations indicated in this test report refer exclusively to the samples tested. It is not permitted to transfer the results to other systems or configurations. The publication or duplication of this test report with enclosures, or Part of this test report or enclosures, without a written consent of the test laboratory is not permitted. The test laboratory not assumes any liability to any party for any loss, expense or damage occasioned by the use of this report. Any use of the laboratories name or one of its marks for the sale or advertisement of the tested material, product or service must first be approved in writing by the test laboratory. In case of a multilingual test report, the English version is the only official version.

§ 22 51999

	Test report n.	813-QL18-R01 ver.0
	Applicant/ Antragsteller	Fondmetal S.p.A. Via Bergamo, 4 24050 Palosco (BG) Italy
	EUT/Type	PKW-Rad - Type FMI04_9520

## 0. Zentrierart / Centering type

Mittenzentrierung

Centering on Hub Flange

## I. Übersicht / Overview

Ausführung/ Version	Kennzeichnung Rad/Zentrierung Wheel identification/ centering rings	Lochzahl/ Lochkreis/ Mittenloch-Ø [mm] Number of holes/ PCD/ centre hole Ø	ET [mm] offset	Radlast [kg] Wheel load	Abroll- umfang [mm] Rolling circum- ference	Gültig ab Herstell- datum Valid from production date
22 5112	FMI04_9520 22 5112 / ohne Ring	5/112/66,5	22	980	2395	06/2018
41 5112	FMI04_9520 41 5112 / ohne Ring	5/112/66,5	41	980	2395	06/2018

## I.1. Beschreibung der Räder / Description of wheels

Handelsmarke Trade mark	FONDMETAL
Art der Räder Type of wheels	Einteiliges Leichtmetall Rad Aluminum One piece wheels
Korrosionsschutz Corrosion protection	Mehrschicht Einbrennlackierung Multilayer Coating , Baked Paint
Masse des Rades Weight of wheel	16,90 kg * ohne Lackierung / Unpainted * Weigth referes to wheel controlled under I.3

## I.2. Radanschluss und Befestigungselemente / Wheel attachment and fastening elements

Siehe Punkt I. Übersicht und Anhaenge

See point I. overview and enclosures

## I.3. Kennzeichnung der Räder / Wheel identification

An den Rädern wird folgende Kennzeichnung an der Außen- bzw. Innenseite eingegossen bzw. eingeprägt, siehe Beispiel Radausführung 41 5112

The following identification will be casted or impressed on the inner and/or outer side of the wheel , see sample wheel version 41 5112

	Außenseite / Outer side	Innenseite / Inner side
Herstellerzeichen / Manufacturer sign	-	FONDMETAL
Radtyp / Wheel type	-	FMI04_9520
Radausführung / Version	-	s.p. I Übersicht / overview
Radgröße / Wheel dimension	-	9,5Jx20 EH2+
Einpreßtiefe / Offset	-	s.p. I Übersicht / overview
Herstellungsdatum / Date of manufacturing	-	Monat und Jahr
Herkunftsmerkmal / Origin	-	Made in Malaysia
Gießerei-kennzeichnung / Casting identification	-	-
KBA Nummer / KBA number	KBA 51999	-
ECE Nummer / ECE number	E3 124R-013096	-

Zusätzlich können auf der Radinnenseite bzw.-außenseite verschiedene Kontrollzeichen angebracht sein.

Additionally other control labels could be affixed on the outer- or inner side of the wheel.

	Test report n.	813-QL18-R01 ver.0
	Applicant/ Antragsteller	Fondmetal S.p.A. Via Bergamo, 4 24050 Palosco (BG) Italy
	EUT/Type	PKW-Rad - Type FMI04_9520

#### I.4. Verwendungsbereich / Application field

Die Räder sind fuer Personenkraftwagen vorgesehen.

The wheels are designated to be mounted on passenger cars.

#### II. Radprüfung / Wheel testing

Die Dauerfestigkeit, der hier beschriebenen Räder, wurde gemäss der "Richtlinien für die Prüfung von Sonderrädern für Kfz und ihren Anh. BMV/StV 13/36.25.07-20.01, VkB1 S 1377" vom 25.11.1998 und ECE-R 124 Änd. 00 Erg. 01 geprüft.

The strength resistance of the wheels described in this report were tested in accordance with the "guidelines for the testing and inspection of special wheels for motor vehicles and their trailers BMV/StV 13/36.25.07-20.01, VkB1 S 1377" from 25<sup>th</sup> of November 1998 and ECE-R 124 Supp. 00 amend. 01

##### II.1. Felge / Rim

Die Maße und Tolleranzen der Felgenkontour entsprechen der E.T.R.T.O. Norm.

Dimensions and tollerances of the rim-contour are in accordance with the E.T.R.T.O.

##### II.2. Werkstoffe der Räder / Materials of wheels

Zusammensetzung, Festigkeitswerte und Korrosionsverhalten des Werkstoffes sind in der Beschreibung des Herstellers aufgefuehrt; diese Angaben wurden durch uns nicht ueberprueft.

Composition, strength values and corrosion behaviour of the materials are listed in the technical description of the manufacturer, these data are not verified by us.

##### II.3. Festigkeitsprüfung / Strength test

###### II.3.1. Dauerfestigkeitsprüfung / Endurance strength test

Prüfinstrument / Measurement instrument:

LEONARDO FR12 QL internal n° QL-IN-069 and Inmess RBT-8K internal n° QL-IN-089

Ausführung/ Version	Lochzahl/Loch- kreis [mm]/ Number of holes/ PCD	ET [mm] Offset	Radlast [kg] Wheel load	Abroll- umfang [mm] Rolling circumference	Prüfmoment Mb max bei 100% [Nm] Bending moment	Anzahl Kurz- zeittest Short time test qty	Anzahl Lang- zeittest Long time test qty
22 5112	5/112	22	980	2395	7019	1	1
41 5112	5/112	41	980	2395	7385	1	1

Die Prüfung wurde mit positivem Ergebnis abgeschlossen (Anrisskontrolle mittels Farbeindringverfahren)

The test was performed with positive result (crack assessment and evaluation: dye penetration method).

###### II.3.2. Abrollprüfung / Rim rolling test

Prüfinstrument / Measurement instrument:

Rim rolling machine GOAL QL internal n° QL-IN-068

Ausführung/ Version	Lochzahl/Loch -kreis-[mm]/ Number of holes/ PCD	ET [mm] Offset	Radlast [kg] Wheel load	Prüf- last [daN] Test Load	Reifengröße Tire dimension	Reifenfüll- druck [bar] Tire pressure	Prüf- distanz [km] Test distance	Anzahl Abroll- test Rolling- Test qty
22 5112	5/112	22	980	2404	305/50 R20	4,5	2000	2
41 5112	5/112	41	980	2404	305/50 R20	4,5	2000	2

Die Prüfung wurde mit positivem Ergebnis abgeschlossen. (Anrisskontrolle mittels Farbeindringverfahren).

Alle anderen Versionen sind abgeleitet.

The test was performed with positive result (crack assessment and evaluation: dye penetration method). All other versions are derived.



Test report n.	813-QL18-R01 ver.0
Applicant/ Antragsteller	Fondmetal S.p.A. Via Bergamo, 4 24050 Palosco (BG) Italy
EUT/Type	PKW-Rad - Type FMI04_9520

**II.3.3. Impact Prüfung / Impact test**

Prüfinstrument / Measurement instrument:  
Impact tester INMESS QL internal n° QL-IN-153

Ausführung/ Version	Lochzahl/Lochkreis [mm]/ Number of holes/ PCD	ET [mm] Offset	Radlast [kg] Wheel load	Fallmasse [kg] Impact weight	Reifengröße Tire dimension	Reifenfüll- druck [bar] Tire pressure	Anzahl Impact- test Impact-Test qty
22 5112	5/112	22	980	768	255/30 R20	2,0	2
41 5112	5/112	41	980	768	255/30 R20	2,0	2

Die Prüfung wurde mit positivem Ergebnis abgeschlossen.  
The test was performed with positive result.

**III. Prüfergebnis / Test result**

Aufgrund der durchgeführten Prüfungen bestehen keine technischen Bedenken o.g. Räder an den in Verwendungsbereichsgutachten genannten Fahrzeugen und den dort aufgeführten Bedingungen zu verwenden.  
Based on the performed tests there are no technical objections to apply the wheels described above to the vehicles listed in the application certificate under fulfillment of the mounting conditions.

**IV. Hinweis / Note**

-

**V. Anlagen /Enclosures**

Beschreibung / Technical description : Radzeichnung / Drawing n° : FMI04_9520__5	Date 20/02/2018 rev.0 date 16/04/2018
---	--

**VI. Datum Bericht und Test /Report and test date**

Ver. 0: 13/08/2018 - Test Date: From 16/07/2018 to 13/08/2018

§ 22 51999

## WHEEL DESCRIPTION

Please find details of wheels supplied to TUV for testing listed below.

Certification request: ABE Document

### 1. General information

- Wheel Type: FMI04\_9520
- Wheel Size: 9.5 J x 20" EH2+
- Tyre type: Tubeless
- Snow chain: See TUV indications
- Face Parallelity and Roundness of Rim: 0.30 mm
- Rim Base: According To Std. E.T.R.T.O.
- Valve Type: Customer Own (STD E.T.R.T.O. 11.3F)
- Balancing Weights: Only Adhesive

### 2. Applications

- All models homologated

### 3. Measurement and other

PART NUMBER		ET	PCD	C.B.	Rings	Bolt & Nuts	Application
FMI04_9520	22 5112	22	5x112	66.5	AA01 (57.1)	OE BOLT V035	Audi, VW, Seat, Skoda, Mercedes
FMI04_9520	41 5112	41	5x112	66.5	AA01 (57.1)	OE BOLT V035	Audi, VW, Seat, Skoda, Mercedes

### 4. Drawings / Accessories

- Wheel drawing numbers: FMI04\_9520\_\_5 rev.0
- Centering: See draw in attachment
- Hubcap: See draw in attachment
- Valve: See draw in attachment
- Wheel Bolt/Nut: See draw in attachment
- Starting Torque the Wheel Nuts: See TUV Indication

### 5. Construction

- Wheel Standard: E.T.R.T.O.
- Construction: One Piece Wheels
- Design: Fondmetal Wheels

## 6. Description of the Wheel Manufacturing

- Features: Gravity casting
- Heat treatment: No
- Machining Process: Fully CNC Machined & CNC drilling
- Varnishing: 3 layer, powder coat, colour paint, lacquer

## 7. Material

- Material: Aluminium alloy G-Al Si7 Mg - T6
- Enervations load: Rp02 70 N/mm2
- Tension strength: Rm 140 N/mm2
- Elongation: A 2%
- Density: 2.65 kg/dm3
- Hardness: Min. 50 HB
- Chemical Analysis:

Silicio Si%	Rame Cu%	Ferro Fe%	Manganese Mn%	Cromo Cr%	Zinco Zn%	Magnesio Mg%	Titanio Ti%	Altro %
6.5 - 7.5	≤ 0.02	≤ 0.15	≤ 0.02	≤ 0.01	≤ 0.03	0.28 - 0.35	0.08 - 0.15	≤ 0.02
Nichel Ni%	Piombo Pb%	Stronzio Sr%	Sodio Na%	Calcio Ca%	Potassio P%	Antimonio Sb%	Cadmio Cd%	Bismuto Bi%
≤ 0.003	≤ 0.0012	0.005 0.012	≤ 0.001	≤ 0.003	≤ 0.001	≤ 0.003	≤ 0.003	≤ 0.003

## 8. Corrosion Consistency of the Material

- Against influence of the water: Very good
- Against seawater: Very good - Minimum 384 hours Corrosion Protection to UNI ISO 9227

## 9. Quality Control

- Material Analysis
- 100% X-Ray Analysis
- Dimensional Inspection Throughout manufacture
- Statistical Process Control on Critical Dimensions
- A 100% tubeless
- A 100% visual inspection

## 10. Production plant

- Casting: YHI Manufacturing (Malaysia) Sdn. Bhd.  
3533, Jalan P.B.R 28,  
Kawasan Perindustrian Bukit Rambai,  
75250 Melaka, MALAYSIA
- Machining Process: YHI Manufacturing (Malaysia) Sdn. Bhd.  
3533, Jalan P.B.R 28,  
Kawasan Perindustrian Bukit Rambai,  
75250 Melaka, MALAYSIA
- Varnishing / Paint Finish: YHI Manufacturing (Malaysia) Sdn. Bhd.  
3533, Jalan P.B.R 28,  
Kawasan Perindustrian Bukit Rambai,  
75250 Melaka, MALAYSIA
- Finish Control: YHI Manufacturing (Malaysia) Sdn. Bhd.  
3533, Jalan P.B.R 28,  
Kawasan Perindustrian Bukit Rambai,  
75250 Melaka, MALAYSIA
- Dispatch/Delivery: Fondmetal Spa, Via Bergamo, Palosco BG

2018-08-06

Ufficio tecnico Fondmetal

§ 22 51999

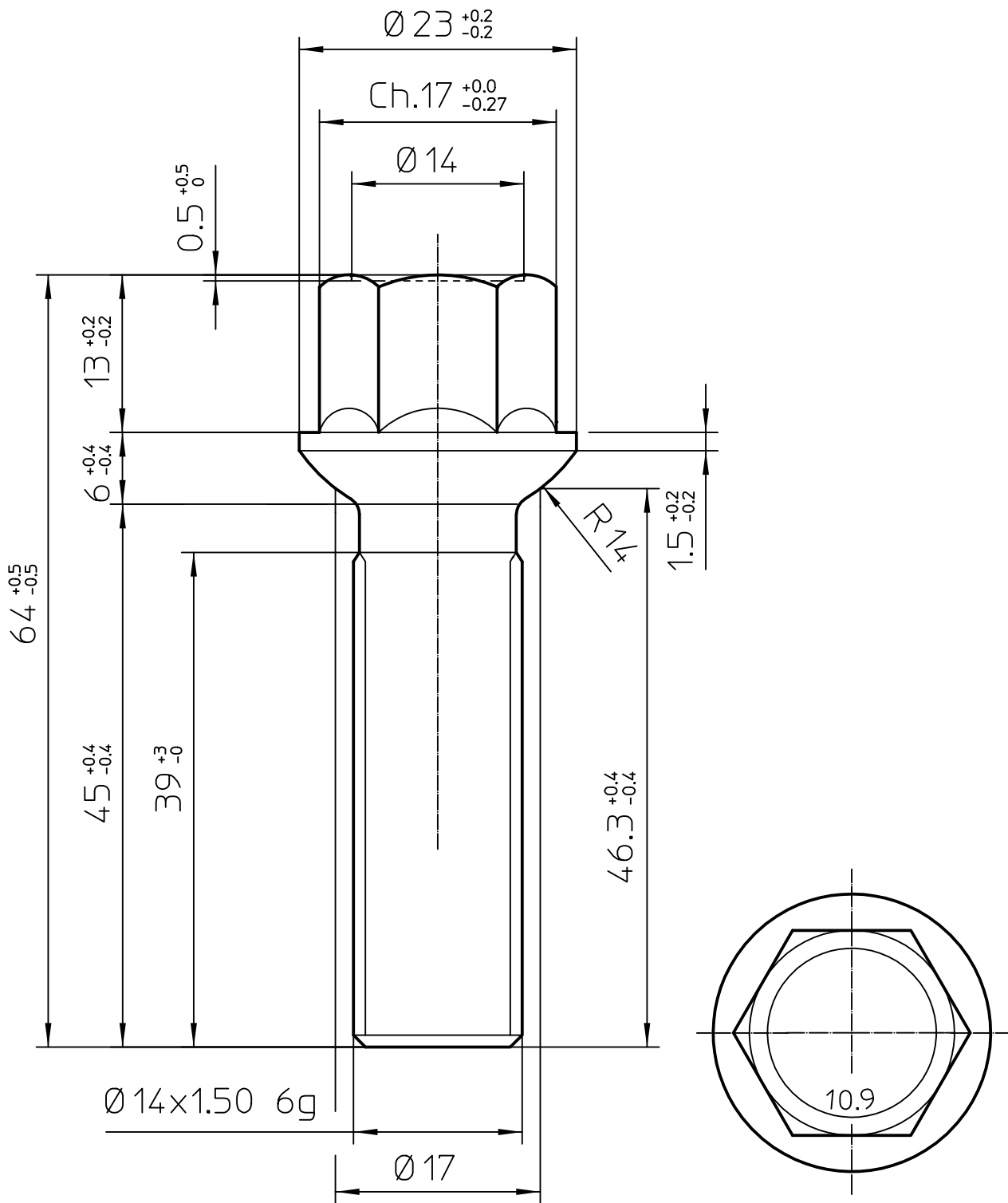

DENOMINAZIONE:  
Beschreibung

VITE M14 x 1.5 ch.17

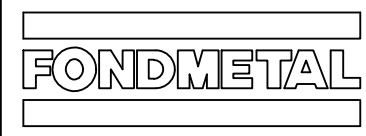
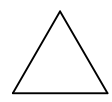

Via BERGAMO 4, PALOSCO (BG) ITALY  
www.fondmetal.com

CODICE PARTICOLARE Teilenummer	V035
DISEGNO N° Zeichnung Nr.	V035
MATERIALE Werkstoff	10.9
FINITURA Lackierung	Lanthane
DISEGNATO DA gezeichnet von	S. RAINERI
CONTROLLATO DA Überprüft von	G. CORIONI
DATA Datum	30/11/17
SCALA Maßstab	2:1
REV.	0

TIPO DI VEICOLO  
FAHRZEUG TYP

CODICE BIMECC:  
S17D45R14



§ 22 51999

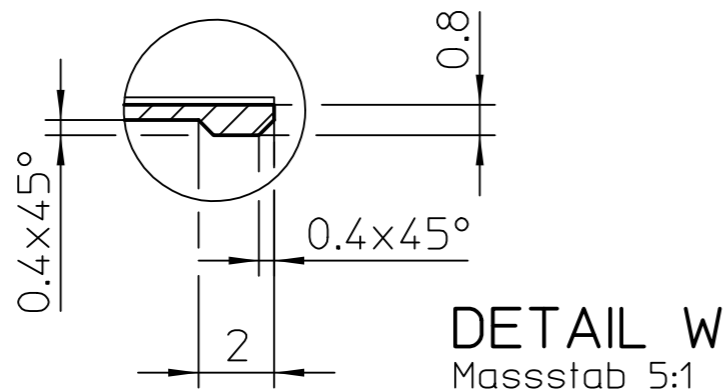
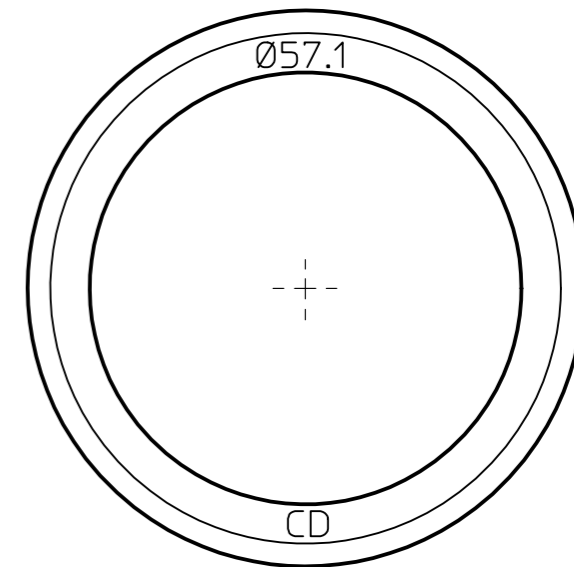
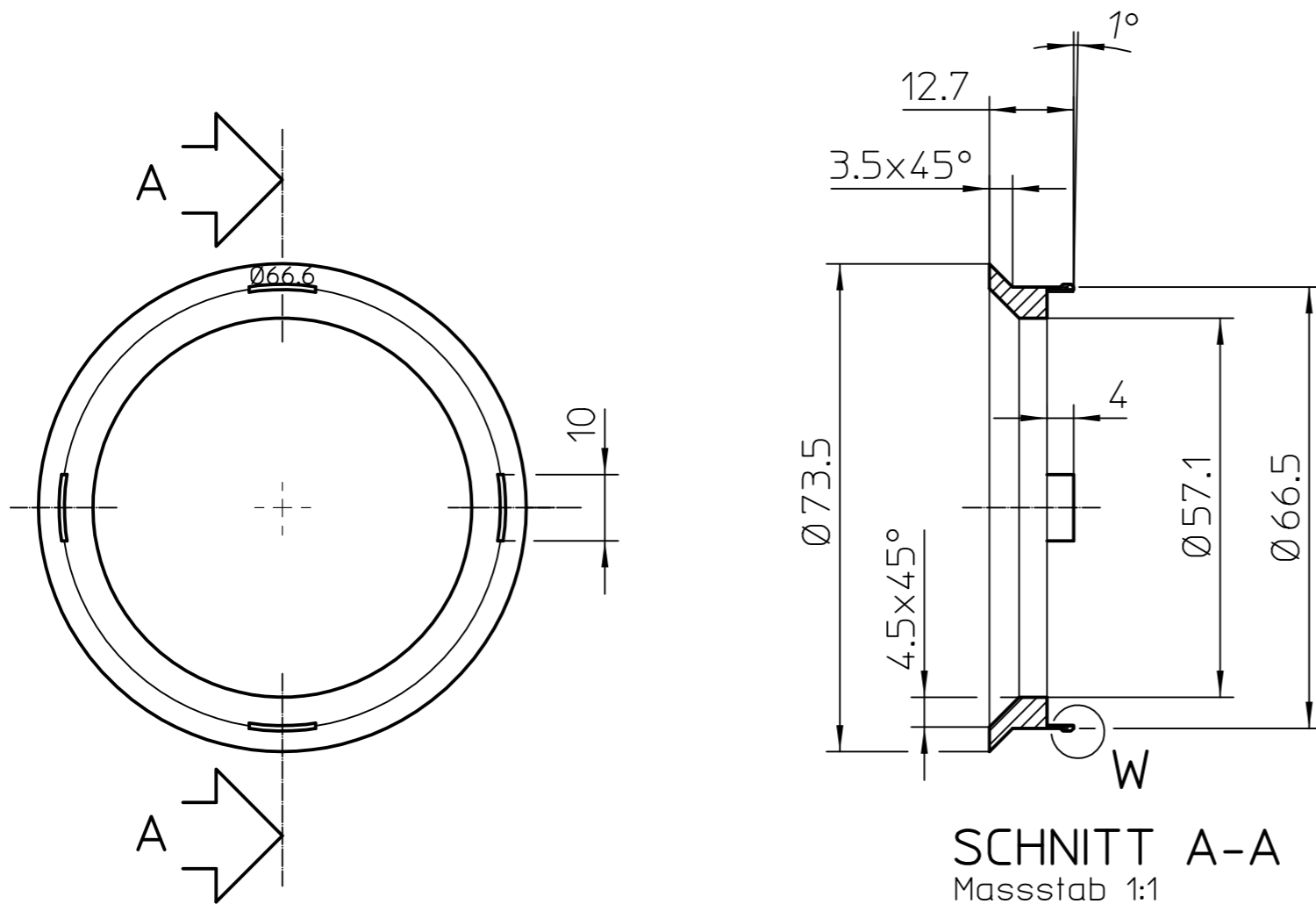

<b>DENOMINAZIONE:</b> Beschreibung		<b>ANELLINO DI CENTRAGGIO</b>			
 Via BERGAMO 4, PALOSCO (BG) ITALY www.fondmetal.com	CODICE PARTICOLARE Teilenummer	AA 01			
	DISEGNO N° Zeichnung Nr.	1AN_AA01			
	MATERIALE Werkstoff	PA66 FV20			
	FINITURA Lackierung	Plastica ROSSO			
	Riferim. Cod. BIMECC Referenz-code BIMECC	AP666571			
	DISEGNATO DA Gezeichnet von	S. FORESTI			
	CONTROLLATO DA Überprüft von	S. RAINERI			
	DATA Datum	22/04/2015	SCALA Maßstab	1:1 (5:1)	
	REV.	A0			

ALLE EIGENTUMSRECHTE VON FONDOMETAL S.P.A. VORBEHALTEN. DER NACHDRUCK ZUR HERSTELLUNG DER HIER DARGESTELLTEN TEILE SOWIE DIE WEITERGABE AN DRITTE DIESER ZEICHNUNG IST, OHNE SCHRIFTLICHE GENEHMIGUNG SEITENS FONDOMETAL S.P.A., UNTERSAGT. JEDLICHE ZUWIDERHANDLUNG WIRD STRAFRECHTLICH VERFOLGT.

TUTTI I DIRITTI DI PROPRIETA' SONO RISERVATI A FONDOMETAL S.P.A.. SENZA AUTORIZZAZIONE DELLA STESSA SE NE VIETA SIA LA RIPRODUZIONE ANCHE SOLO PARZIALE PER LA COSTRUZIONE DEI PEZZI RAPPRESENTATI, SIA LA COMUNICAZIONE A TERZI DEL PRESENTE DISEGNO. QUALSIASI INOSSERVANZA VIENE PUNITA A NORMA DI LEGGE.

MR87G-2095与MK519-2095共口模。

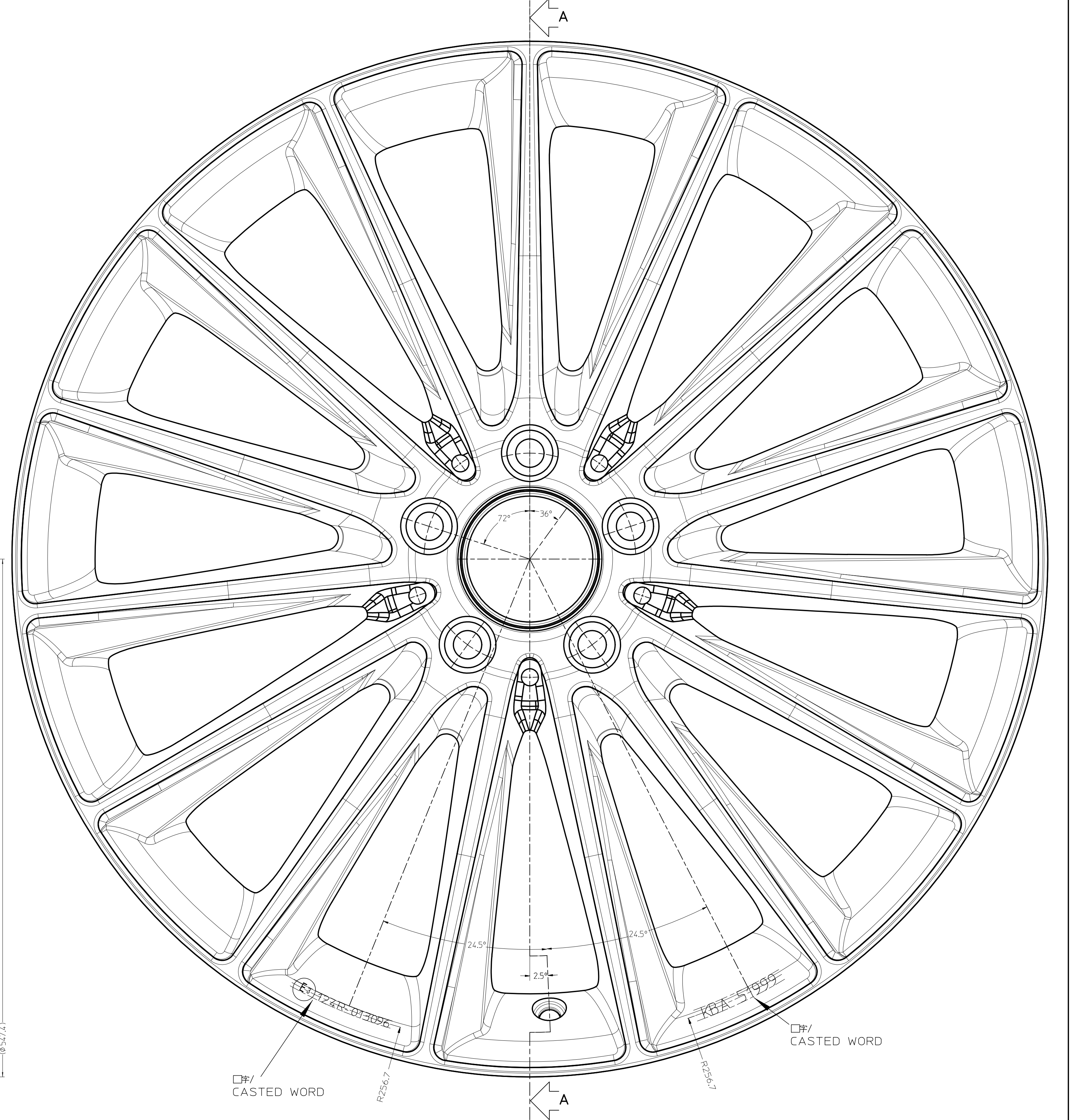
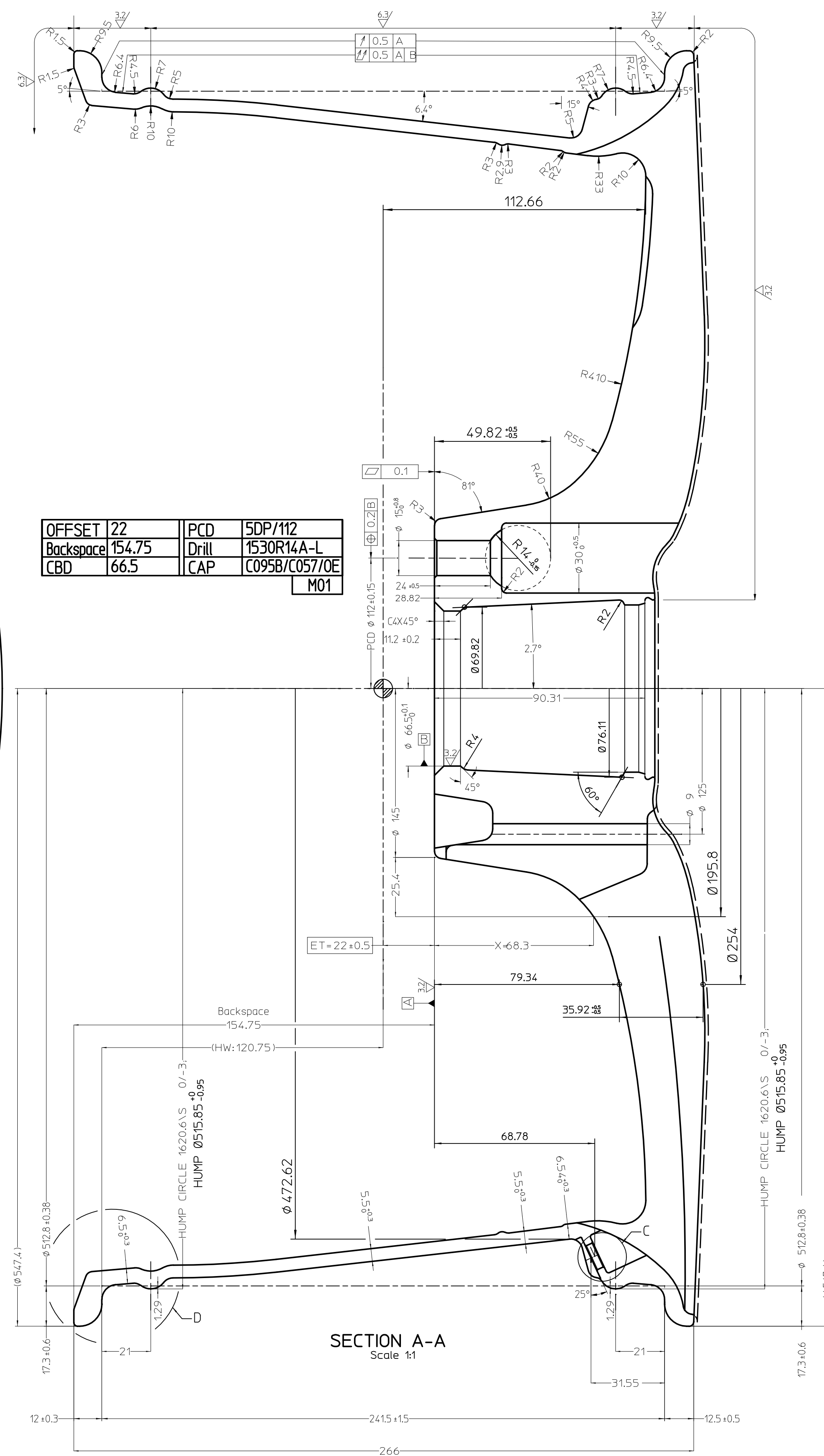
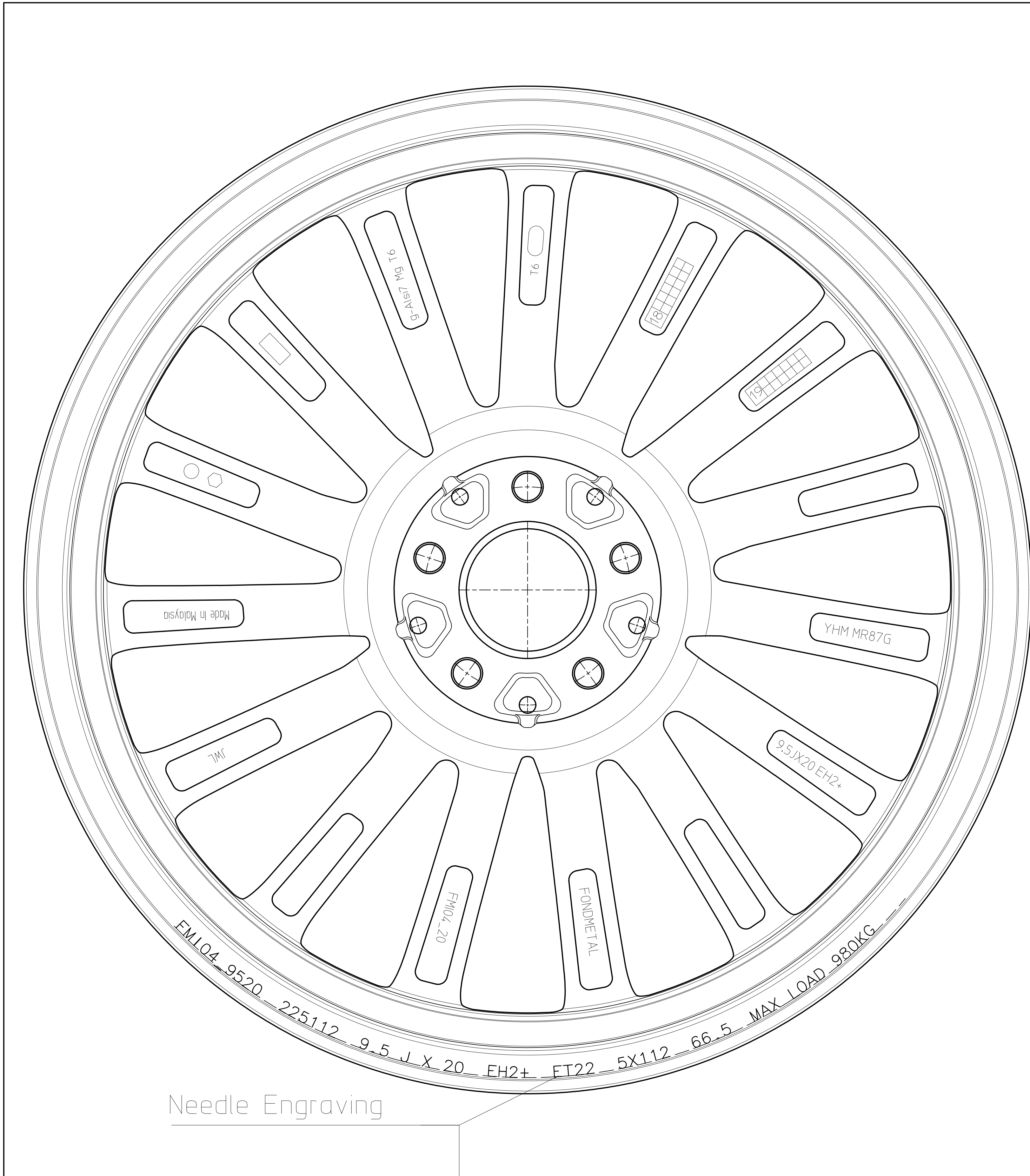

OFFSET	22	PCD	SDP/112
Backspace	154.75	Drill	F530R14A-L
CBD	66.5	CAP	C095B/C057/OE

SECTION A-A  
Scale 1:1

Rear 'J' engrave contents :

Spec	Content
1	ET22 5X112 66.5 FM104_9520 225112 9.5JX20 EH2+ ET22 5X112 66.5 MAX LOAD 980KG
2	ET41 5X112 66.5 FM104_9520 415112 9.5JX20 EH2+ ET41 5X112 66.5 MAX LOAD 980KG

Inscription Content

Front	Content	Remarks
1	124R-013096	
2	KBA 51999	
3		
Back		
1	MR87G	Model
2	9.5JX20 EH2+	Size
3	FONDOMETAL FM104_20	Customer Model Code
4	JWL	
5	Made in Malaysia	
6	○	Air Leak Test Staff No.
7	○	CNC Staff No.
8	g-Als17 Mg T6	
9	○	Heat Treatment No.
10	○	Casting Staff No.
11	18	Casting Year/Month
12	19	Casting Year/Month
13	YHM	

CNC Method	M01	M02
PCD Hole	50P	50P
PCD	112	112
HUB	66.5	66.5
PCDD	F530R14A-L	F530R14A-L
ET	22	41
PAD	Ø145	Ø145

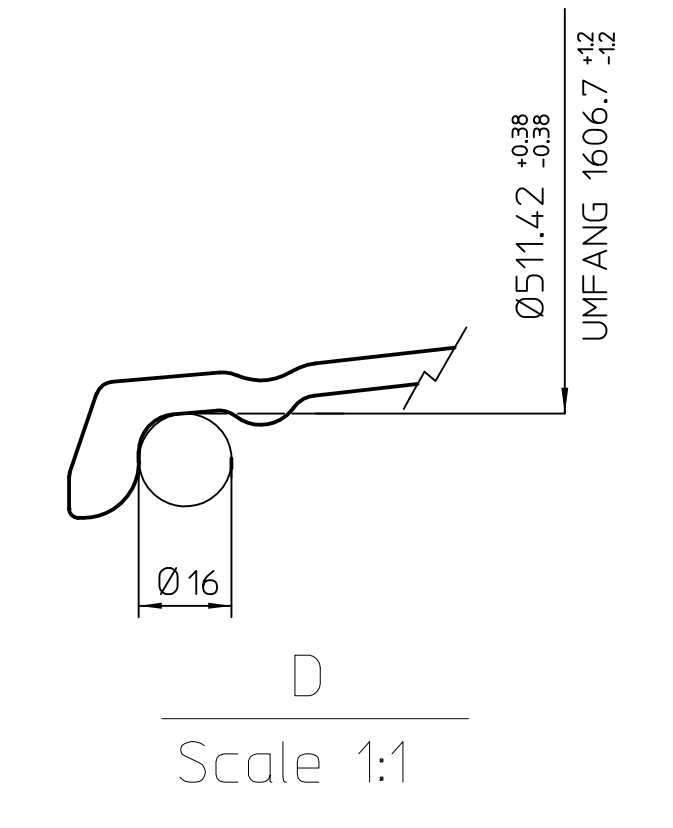
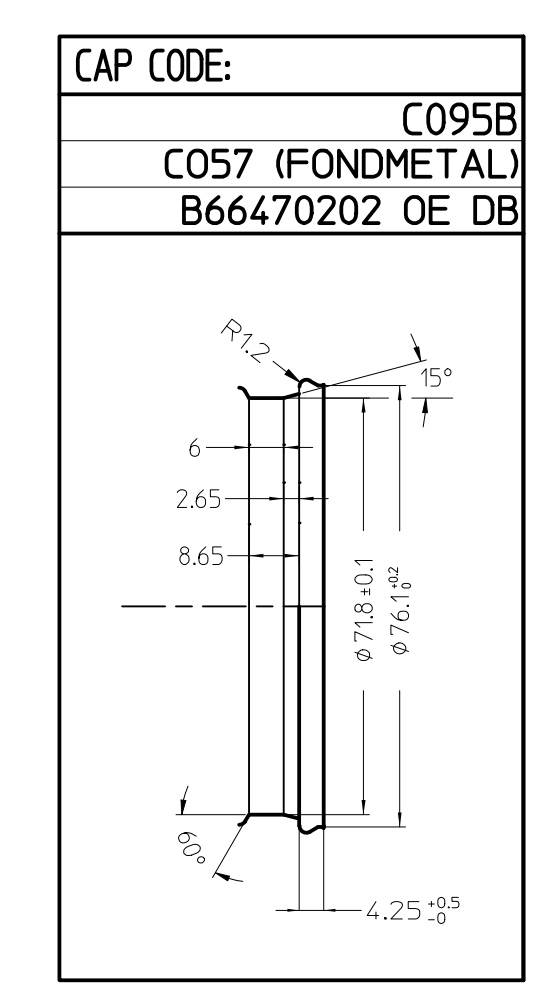
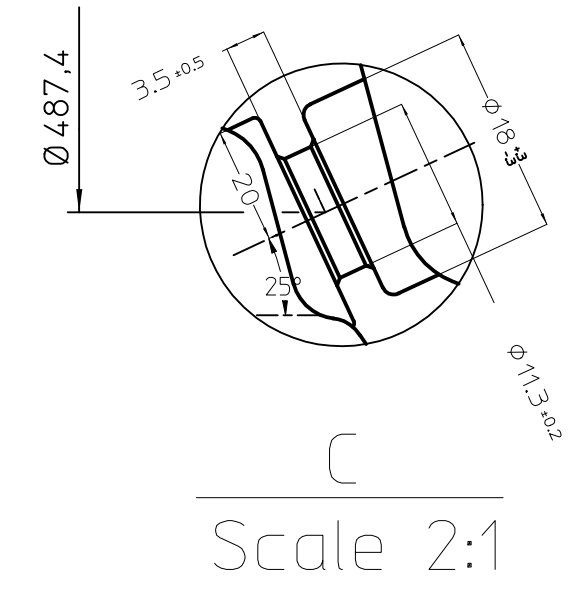
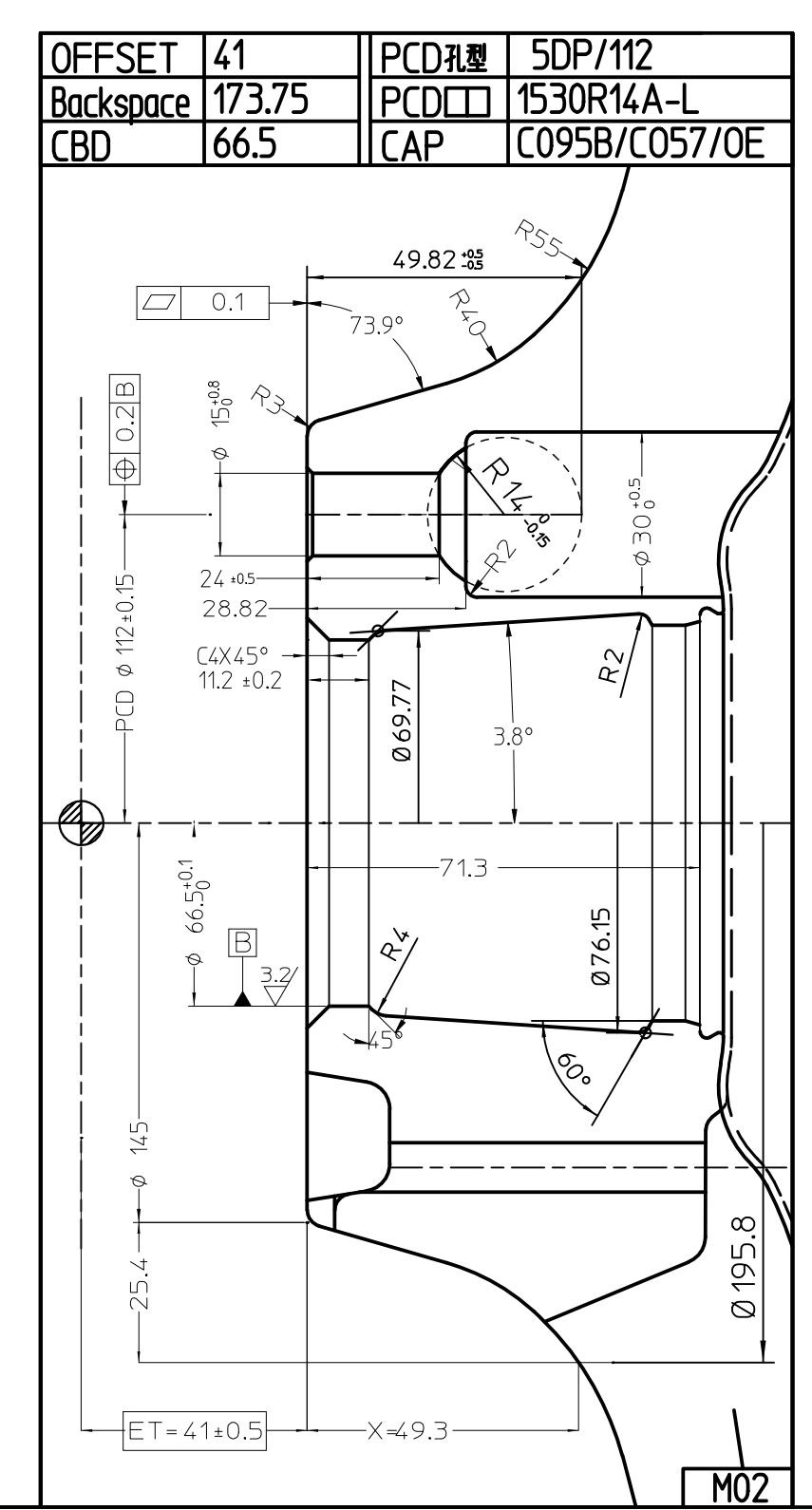

TYPE	FM104_9520
SIZE	9.5JX20EH2+
SCALE	1:1 (2:1)
DATE	16/04/2018
DESIGNER	YHM
CHECKER	YHM
APPROVED	YHM

DB MERCEDES	FM104_9520	22	112	66.5	5
DB MERCEDES	FM104_9520	41	112	66.5	5
VEHICLE BRAND	TYPE	ET	PCD	C.B.	MAX INTERASSE

Inscription width mm, height 0.6-0.8mm	ORIGINAL DRAWING DATE	Max. Load Index 980KG
Unspecified Tolerance	Wheel weight KG	
More than 1 less than 4	±0.1	
More than 4 less than 16	±0.2	
More than 16 less than 63	±0.3	
More than 63 less than 250	±0.5	
More than 250 less than 1000	±0.8	
More than 1000 less than 2000	±1	

Mark	Place	Content	Signature	Date

## Pommerencke, Nino

---

**Von:** Pommerencke, Nino  
**Gesendet:** Montag, 1. Oktober 2018 13:51  
**An:** 'Wolff, Ralf'  
**Cc:** SachbearbeiterGB1  
**Betreff:** GA RA-000976-A0-072; ABE 51999; FMI04\_9520; Fondmetal S.p.A.

Sehr geehrter Herr Wolff,

im Verwendungsbereich sind kleinere Reifen enthalten, als bei der Impactprüfung geprüft wurden. Nach Rädli muss der Reifen mit dem kleinsten Nenndurchmesser bei der Impact-Prüfung gewählt werden.

Nach Qualilab wurde beim Impacttest die Reifengröße 255/30 R20 verwendet. Dies ist der kleinste Reifen, welcher für das Rad 9, 5 J x 20 EH2+ im VWB angegeben werden darf.

Typ(en):		ABE / EG-Genehmigung(en):
F2		e1*2007/46*1801*..
Motorleistung (kW)	Handelsbezeichnungen	zulässige Reifengrößen vorne und hinten, ggf. Auflagen
150	Audi A6 (Limousine, Frontantrieb)	235/40R20 A01)K01)K02)N245)  255/35R20 A01)K01)K02)

Abbildung 1: Aus Anlage 1 S. 2/11; Audi

Bitte prüfen Sie die Angaben im Verwendungsbereich und senden Sie mir ein Austauschgutachten zu.

Haben Sie vielen Dank!

Mit freundlichen Grüßen

**Nino Pommerencke**

Kraftfahrt-Bundesamt  
Nino Pommerencke  
Abteilung Typpgenehmigung  
24932 Flensburg

Telefon: 0461 316-1361  
Telefax: 0461 316-1740

E-Mail: [Nino.Pommerencke@kba.de](mailto:Nino.Pommerencke@kba.de)  
Internet: [www.kba.de](http://www.kba.de)